

2/2-way-valves DN 15 to DN 50

For neutral gases and liquid fluids
Solenoid actuated, with forced lifting
Piston valves

Flange connection, pressure rating PN 40
Operating pressure 0 to 25 bar (40 bar)

85500

Description (standard valve)

Solenoid valve for e.g. air, water, oil

Switching function:	normally closed
Flow direction:	determined
Fluid temperature:	-20 °C up to max. +90 °C
Ambient temperature:	-20 °C up to max. +50 °C
Mounting position:	optional, preferably solenoid vertical on top

Material

Body:	Cast steel, Brass
Seat seal:	NBR
Internal parts:	Stainless steel, PTFE / Carbon

Click-on[®]



For contaminated fluids insertion of a strainer is recommended (see **Buschjost** - accessories).

Features

- High flow rate
- For robust industry solutions
- Damped operation
- Suitable for vacuum
- For systems with low or fluctuating pressure
- Stainless steel piston
- Valve operates without differential pressure (Zero Delta P)
- Solenoid interchangeable without tools (**Click-on**[®]) up to DN 25
- Fluids of Group 2 acc. Pressure Equipment Directive 97/23/EC

Symbol

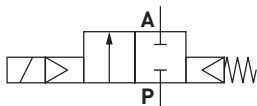

Ordering information

To order, quote model number from table overleaf, e.g. 8550400.9401 for a DN 25 valve.

Characteristic data

Valves

Part Number Solenoid with ≡	Part Number Solenoid with ~	Nominal Diameter (mm)	Operating pressure *		K _v -value ** (Base m ³ /h)	Weight (kg)
			min. (bar)	max. (bar)		
8550200.9401	8550200.9404	15	0	25	4.4	3.8
8550300.9401	8550300.9404	20	0	25	7.0	4.2
8550400.9401	8550400.9404	25	0	25	10.5	4.8
8550500.8401	8550500.8404	32	0	25	25.0	9.6
8550600.8401	8550600.8404	40	0	25	27.0	10.0
8550700.8401	8550700.8404	50	0	25	43.0	11.5

* for gases and liquid fluids up to 60 mm²/s (cSt)

State voltage [V] and frequency [Hz]

** C_v-value (US) ≈ kv-value x 1.2

Solenoid 9401 / 9404 and 8401 / 8404

Standard voltages

DC ≡	AC ~ 40 Hz - 60 Hz
24 V	24 V
-	110 V
-	120 V
-	230 V

Design acc.to DIN VDE 0580

voltage range ±10 %

100 % duty cycle

Protection class acc.to EN 60529 IP65

Socket Form A acc.to DIN EN 175301-803 (included)

AC solenoid with rectifier plug

Power Consumption

According to DIN VDE 0580 at coil temperature von +20 °C. In operation the power consumption of the solenoid decreases by approx. 30 %.

Solenoid	DC ≡	AC ~	
		Inrush	Holding
9401 *	38 W		
9404 *		42 VA	42 VA
8401	40 W		
8404		45 VA	45 VA

*  coil only

(With the exception of solenoid 94XX up to 41 V AC)

Attention!

The conditions imposed on the Ex approvals lead to reduction of the permissible standard temperature ranges in the case of explosion protected solenoids.

Further Options (Valves)

XXXXX01.XXXX Normally open (NO), only with solenoid 8400, mounting position: solenoid vertical on top

XXXXX02.XXXX Manual override

XXXXX03.XXXX Seat seal FPM, fluid temperature -10 °C up to +110 °C ¹⁾

XXXXX06.XXXX Seat seal PTFE, fluid temperature -20 °C up to +110 °C ¹⁾, leakage rate E acc. to DIN EN 12266-1

XXXXX14.XXXX Seat seal EPDM, fluid temperature -20 °C up to +110 °C

XXXXX17.XXXX Normally open, Seat seal FPM, fluid temperature -10 °C up to +110 °C, mounting position: solenoid vertical on top ¹⁾, only with solenoid 8400

XXXXX22.XXXX max. operating pressure 40 bar

XXXXX23.XXXX Electrical position indicator with two magnetic field sensors (only solenoid 8400)

XXXXX25.XXXX Seat seal FPM, with larger bleed orifices in the piston, for e.g. fuel and oil, max. viscosity 80 mm²/s (cSt), fluid temperature -10 °C up to +110 °C ¹⁾

XXXXX47.XXXX Flanges acc. to ASME B 16.5 150 lb/sq. In.

XXXXX48.XXXX Flanges acc. to ASME B 16.5 300 lb/sq. In.

On request Further versions

Further Options (Solenoids)

XXXXXXXX.8441 Protection class  II 2 GD EEx me II T3 T 140 °C

XXXXXXXX.9426 * Protection class  II 3 GD EEx nA II T4 T 135 °C

XXXXXXXX.8426 * Protection class  II 3 GD EEx nA II T4 T 135 °C

XXXXXXXX.8920 Protection class  II 2 GD EEx d ll C T4 and T5 T 130 °C / 95 °C

On request Further versions

* DC only, for AC solenoids with design inspection certificate acc. to category 2, e.g. XXXXXX.8441

¹⁾ Up to max. +200 °C fluid temperature with solenoid for higher temperature

Section View

up to DN 25

- 101 Valve body
- 102 Valve cover
- *103 Valve piston
- 104 Straight pin
- *105 Pressure spring
- *106 Seal ring
- *107 O-ring
- *108 Grooved ring
- 400 Solenoid
- 701 Core tube
- *702 Straight pin
- 703 Round plate
- *704 Pressure spring
- *705 Core
- 706 Spring clip
- *707 O-ring
- 1400 Socket (included)

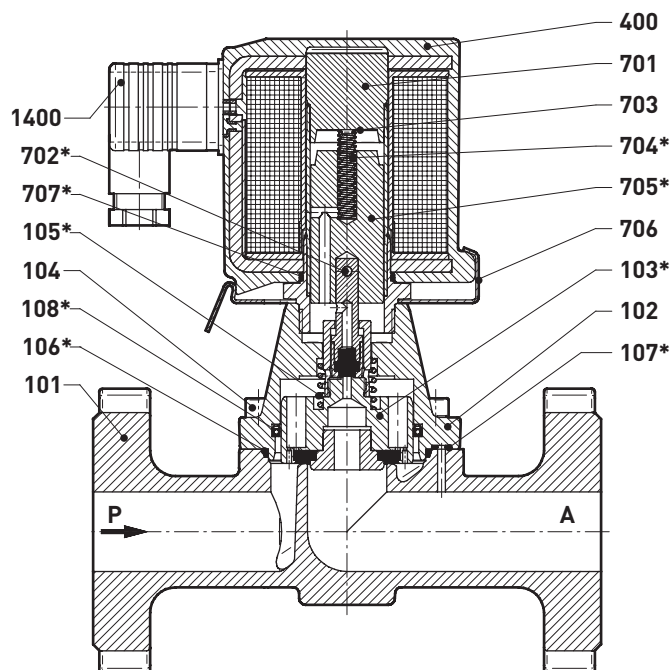

from DN 32

- 101 Valve body
- 102 Valve cover
- *103 Valve piston
- 104 Straight pin
- *105 Pressure spring [2x]
- *106 Seal ring
- *107 O-ring
- *108 Grooved ring
- 400 Solenoid
- 701 Core tube
- *702 Straight pin
- 703 Round plate
- *704 Pressure spring
- *705 Core
- 1400 Socket (included)
- 1501 Hexagon screw
- 1502 Round plate
- *1504 O-ring [2x]

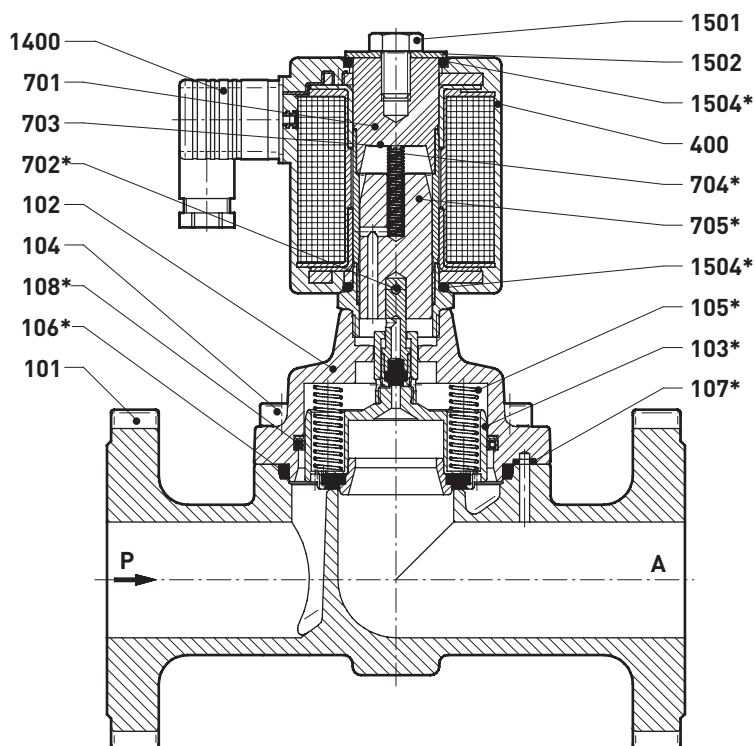

* These individual parts form a complete wearing unit.
When ordering spare parts please state Cat No and Series No.

General Dimensions

Solenoid rotatable 360°
 Socket turnable 4 x 90°
 (Socket included)

up to DN 25

from DN 32

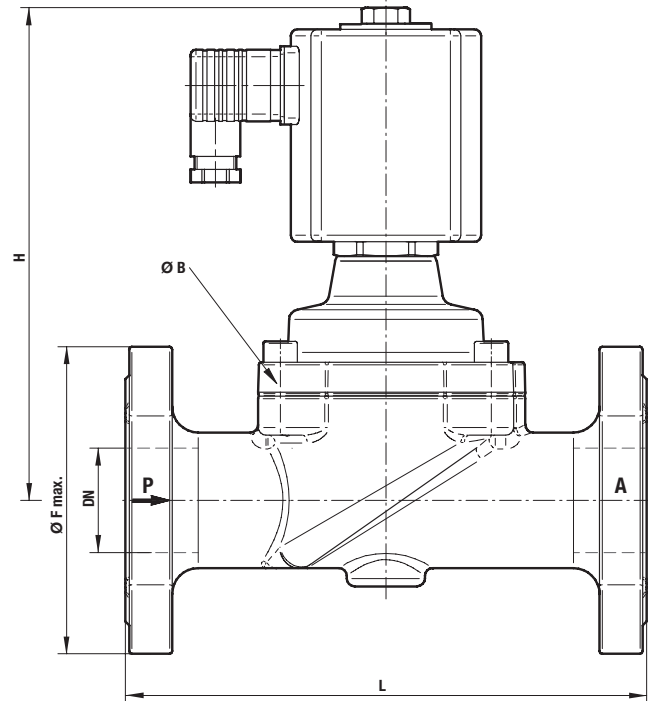
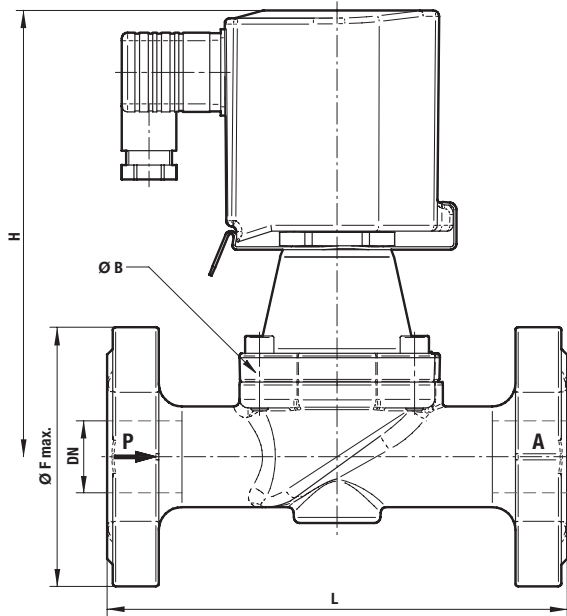

Part Number	Nominal Diameter (mm)	L (mm)	H (mm)	Ø F max. (mm)	Ø B (mm)
8550200.940x	15	130	142	96	44
8550300.940x	20	150	150	110	50
8550400.940x	25	160	155	115	62
8550500.840x	32	180	184	140	92
8550600.840x	40	200	189	150	92
8550700.840x	50	230	197	165	109

Contact face acc. to DIN EN 1092-1/B

Note to Pressure Equipment Directive (PED):

The valves of this series are according to Art. 3 § 3 of the Pressure Equipment Directive (PED) 97/23/EG. This means interpretation and production are in accordance to engineers practice wellknown in the member countries.

The CE-sign at the valve refers not to the PED. Thus the declaration of conformity is not longer applicable for this directive.

Note to Electromagnetic Compatibility Guideline (EEC):

The valves shall be provided with an electrical circuit which ensures the limits of the harmonised standards EN 61000-6-3 and EN 61000-6-1 are observed, and hence the requirements of the Electromagnetic Compatibility Guideline (2004/108/EG) satisfied.