

Valve operates without differential pressure

Valve with PTFE piston guide rings

Suitable for vacuum



Technical features

Medium:

Air, water and oil

Switching function:

Normally closed

Operation:

Solenoid actuated,
with forced lifting

Mounting position:

Optional,
preferably solenoid
vertical on top

Flow direction:

Determined

Port size:

G1/4, G3/8, G1/2, G3/4, G1,
G1 1/4, G1 1/2, G2
1/4 NPT, 3/8 NPT, 1/2 NPT,
3/4 NPT, 1 NPT, 1 1/4 NPT,
1 1/2 NPT, 2 NPT

Operating pressure:

0 ... 25 bar
(0 ... 40 bar)

Fluid temperature:

-20 ... +90°C

Ambient temperature:

-20 ... +50°C

Material:

Body: Brass (CW617N)

Seat seal: NBR

Internal parts:

Stainless steel, PTFE/Carbon

For contaminated fluids insertion
of a strainer is recommended.

Technical data - standard models

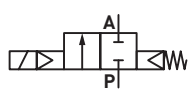
Symbol	Port size	Orifice (mm)	Flow kv value *1) (m ² /h)	Operating pressure *2) (bar)	Weight (kg)	Model Solenoid in V d.c.	Model Solenoid in V a.c.
	G1/4	8	2,2	0 ... 25	1,5	8670000.8301.xxxxx	8670000.8304.xxxxx
	1/4 NPT	8	2,2	0 ... 25	1,5	8671000.8301.xxxxx	8671000.8304.xxxxx
	G3/8	10	3,4	0 ... 25	1,5	8670100.8301.xxxxx	8670100.8304.xxxxx
	3/8 NPT	10	3,4	0 ... 25	1,5	8671100.8301.xxxxx	8671100.8304.xxxxx
	G1/2	12	4,4	0 ... 25	1,6	8670200.8301.xxxxx	8670200.8304.xxxxx
	1/2 NPT	12	4,4	0 ... 25	1,6	8671200.8301.xxxxx	8671200.8304.xxxxx
	G3/4	20	6,5	0 ... 25	1,8	8670300.8301.xxxxx	8670300.8304.xxxxx
	3/4 NPT	20	6,5	0 ... 25	1,8	8671300.8301.xxxxx	8671300.8304.xxxxx
	G1	25	10	0 ... 25	2,2	8670400.8301.xxxxx	8670400.8304.xxxxx
	1 NPT	25	10	0 ... 25	2,2	8671400.8301.xxxxx	8671400.8304.xxxxx
	G1 1/4	32	24	0 ... 25	5,6	8670500.8401.xxxxx	8670500.8404.xxxxx
	1 1/4 NPT	32	24	0 ... 25	5,6	8671500.8401.xxxxx	8671500.8404.xxxxx
	G1 1/2	40	25	0 ... 25	5,4	8670600.8401.xxxxx	8670600.8404.xxxxx
	1 1/2 NPT	40	25	0 ... 25	5,4	8671600.8401.xxxxx	8671600.8404.xxxxx
	G2	50	41	0 ... 25	6,8	8670700.8401.xxxxx	8670700.8404.xxxxx
	2 NPT	50	41	0 ... 25	6,8	8671700.8401.xxxxx	8671700.8404.xxxxx

xxxxx Please insert voltage and frequency codes

*1) Cv-value (US) ≈ kv value x 1,2

*2) For gases and liquid fluids up to 40 mm²/s (cSt)

Option selector
867★ ★ ★ ★ . ★ ★ ★ ★ . ★ ★ ★ ★ ★

Thread form	Substitute
ISO G	0
NPT	1
Port size	Substitute
1/4	0
3/8	1
1/2	2
3/4	3
1	4
1 1/4	5
1 1/2	6
2	7
Valve options	Substitute
Normally open (NO), Mounting position: Solenoid vertical on top	01
Manual override, with solenoid 8400	02
Seat seal FPM, Fluid temperature -10 ... +110°C *1)	03
Seat seal PTFE, max. fluid temperature +110°C *1), G1/4 ... 1 with solenoid 8300 Operating pressure 25 bar	06
Seat seal EPDM, max. fluid temperature +110°C	14
Normally open (NO), Seat seal FPM, Fluid temperature -10 ... +110°C *1), Mounting position: Solenoid vertical on top	17
Max. operating pressure 40 bar, with solenoid 8400	22
Position indicator, with solenoid 8400	23
Seat seal FPM, with larger bleed orifices in the piston, for fluids such as fuel and oil, viscosity max. 80 mm ² /s (cSt), Fluid temperature -10 ... +110°C *1), with solenoid 8400	25

Frequency	Substitute
See table frequency codes	xx
Voltage	Substitute
See Voltage codes	xxx
Solenoid options	Substitute
G1/4 ... 1 Solenoid in V d.c.	8301
G1 1/4 ... 2 Solenoid in V d.c.	8401
G1/4 ... 1 Solenoid in V a.c.	8304
G1 1/4 ... 2 Solenoid in V a.c.	8404

Standard solenoid systems

Voltage and Frequency Solenoid 8301/8304					
Code	Code	Voltage	Frequency	Power consumption	
				Inrush	Holding
024	00	24 V d.c.	-	22 W	22 W
024	49	24 V a.c. *2)	40 ... 60 Hz	25 VA	25 VA
110	49	110 V a.c. *2)	40 ... 60 Hz	25 VA	25 VA
120	49	120 V a.c. *2)	40 ... 60 Hz	25 VA	25 VA
230	49	230 V a.c. *2)	40 ... 60 Hz	25 VA	25 VA
Voltage and Frequency Solenoid 8401/8404					
024	00	24 V d.c.	-	40 W	40 W
024	49	24 V a.c. *2)	40 ... 60 Hz	45 VA	45 VA
110	49	110 V a.c. *2)	40 ... 60 Hz	45 VA	45 VA
120	49	120 V a.c. *2)	40 ... 60 Hz	45 VA	45 VA
230	49	230 V a.c. *2)	40 ... 60 Hz	45 VA	45 VA

*2) a.c. only with rectifier plug

Further versions on request!
Electrical details for all solenoid systems

Design	DIN VDE 0580
Voltage range	±10%
Duty cycle	100% ED
Protection class	EN 60529 IP65
Socket	Form A acc. to DIN EN 175301-803 (included)

According to DIN VDE 0580 at a solenoid temperature of +20°C.
At operating state temperature the input power of a coil decreases by up to ca. 30% due to physical reasons.

Additional solenoid systems

ATEX category	Protection class	Solenoid	Standard voltages
II2GD	EEx me II T3 T 140°C	8441	24 V d.c., 110 V a.c., 230 V a.c.
II3GD	Ex nA II T4 T 135°C *3)	8326	24 V d.c., 110 V a.c., 230 V a.c.
II3GD	Ex nA II T4 T 135°C *3)	8426	24 V d.c., 110 V a.c., 230 V a.c.

Attention!

The conditions imposed on the Ex approvals lead to reduction of the permissible standard temperature ranges in the cases of explosion protected solenoids.

*1) Up to max. 200°C fluid temperature with solenoid for higher temperature

*3) Only d.c., for a.c. solenoids with design inspection certificate acc. to category 2, e.g. XXXXXX.8441

Section View
G1/4 ... 1
1/4 ... 1 NPT

No.	Description
101	Valve body
102	Valve cover
*103	Valve piston
104	Socket head cap screw
*105	Pressure spring
*106	Seal ring
*107	O-Ring
400	Solenoid
701	Core tube
*702	Straight pin
703	Round plate
*704	Pressure spring
*705	Core
1400	Socket (included)
1501	Hexagon screw
1502	Round plate
1504	Gasket
1505	O-Ring

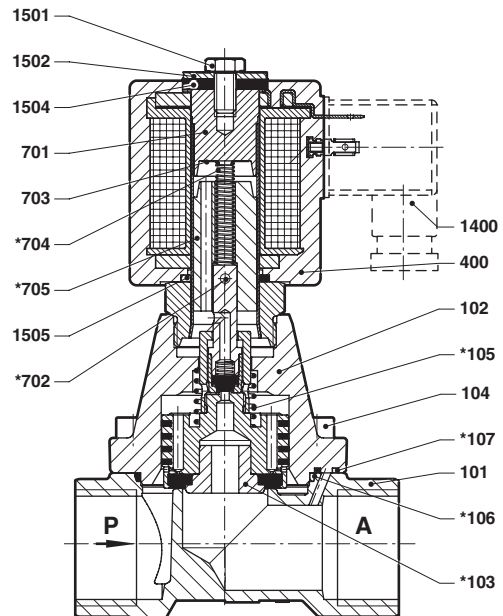
G1 1/4 ... 2
1 1/4 ... 2 NPT

No.	Description
101	Valve body
102	Valve cover
*103	Valve piston
104	Socket head cap screw
*105	Pressure spring
*106	Seal ring
*107	O-Ring
400	Solenoid
701	Core tube
*702	Straight pin
703	Round plate
*704	Pressure spring
*705	Core
1400	Socket (included)
1501	Hexagon screw
1502	Gasket
1504	O-Ring

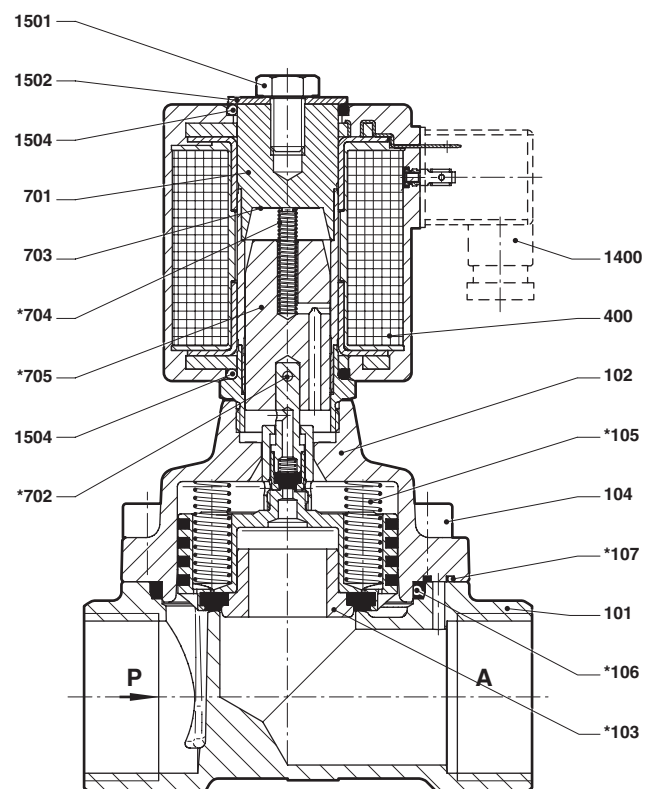

* These individual parts form a complete wearing unit.
 When ordering spare parts please state Model No. and Series No.

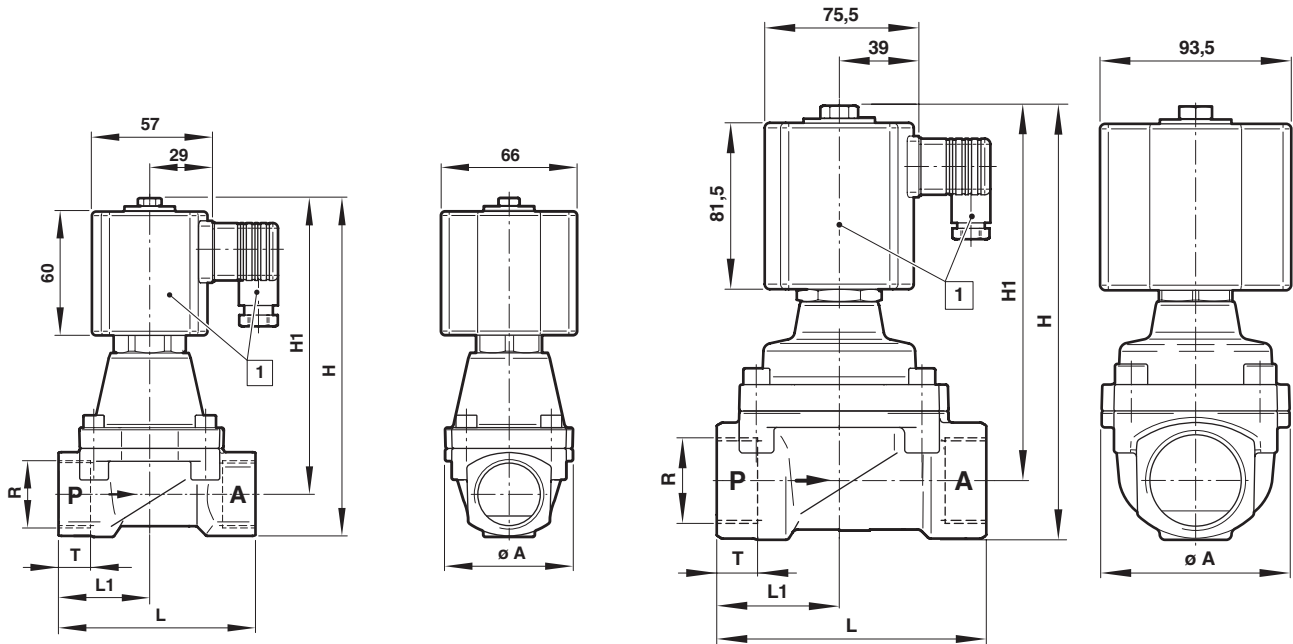
Dimensions
G1/4 ... 1
1/4 ... 1 NPT
G1 1/4 ... 2
1 1/4 ... 2 NPT

1 Solenoid rotatable 360°
 Socket turnable 4 x 90°
 [Socket included]

Port size R	ø A	H	H1	L	L1	T	Model
G1/4	44	143	132	60	27,5	12	8670000.830x.xxxxx
1/4 NPT	44	143	132	60	27,5	10	8671000.830x.xxxxx
G3/8	44	143	132	60	27,5	12	8670100.830x.xxxxx
3/8 NPT	44	143	132	60	27,5	10,5	8671100.830x.xxxxx
G1/2	44	145	132	67	31	14	8670200.830x.xxxxx
1/2 NPT	44	145	132	67	31	13,5	8671200.830x.xxxxx
G3/4	50	154	137	80	35,5	16	8670300.830x.xxxxx
3/4 NPT	50	154	137	80	35,5	14	8671300.830x.xxxxx
G1	62	164	143,5	95	44	18	8670400.830x.xxxxx
1 NPT	62	164	143,5	95	44	17	8671400.830x.xxxxx
G1 1/4	92	212,5	183,5	132	60	20	8670500.840x.xxxxx
1 1/4 NPT	92	212,5	183,5	132	60	17	8671500.840x.xxxxx
G1 1/2	92	212,5	183,5	132	60	22	8670600.840x.xxxxx
1 1/2 NPT	92	212,5	183,5	132	60	17	8671600.840x.xxxxx
G2	109	212,5	183,5	160	74	24	8670700.840x.xxxxx
2 NPT	109	212,5	183,5	160	74	17,5	8671700.840x.xxxxx

Note to Pressure Equipment Directive (PED):

The valves of this series, including the connection size DN 25 (G 1), are according to Art. 3 § 3 of the Pressure Equipment Directive (PED) 97/23/EG. This means interpretation and production are in accordance to engineers practice wellknown in the member countries.

The CE-sign at the valve refers not to the PED. Thus the declaration of conformity is not longer applicable for this directive.

For valves > DN 25 (G 1) Art. 3 § (1) No.1.4 applies.

The basic requirements of the Enclosure I of the PED must be fulfilled. The CE-sign at the valve includes the PED. A certificate of conformity of this directive will be available on request.

Note to Electromagnetic Compatibility Guideline (EEC):

The valves shall be provided with an electrical circuit which ensures the limits of the harmonised standards EN 61000-6-3 and EN 61000-6-1 are observed, and hence the requirements of the Electromagnetic Compatibility Guideline (2004/108/EG) satisfied.