

**COMPACT
SHORT STROKE CYLINDERS
KSE-A SERIES Ø20- Ø100**

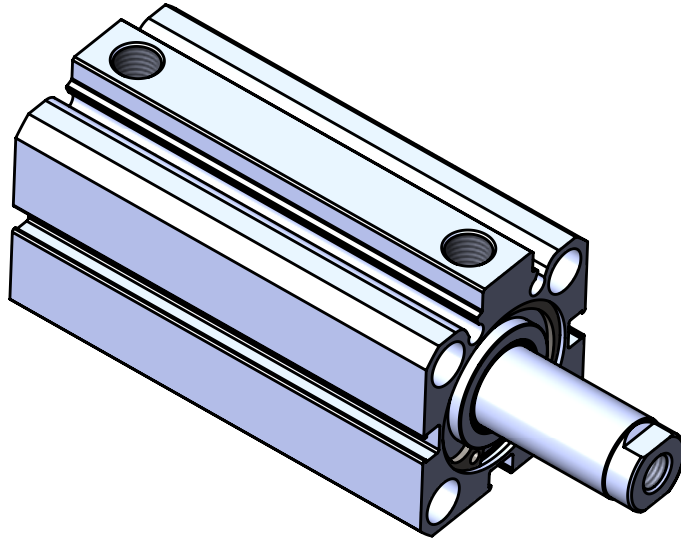

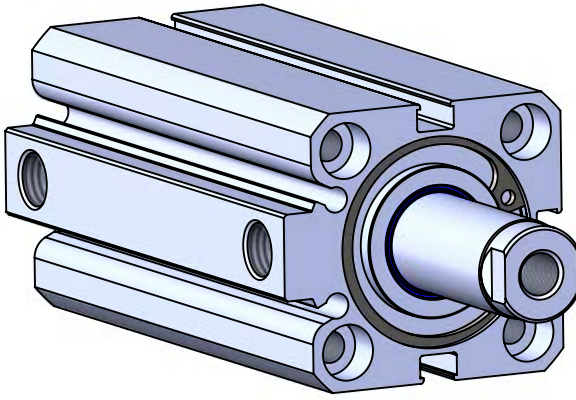

KSE-A SERIES
SHORT STROKE CYLINDER
Ø20 - Ø100

SHORT STROKE
WITH MAGNET AND REAR SPRING

WITH SINGLE ACTING USAGE PROVIDES
MINIMUM AIR CONSUMPTION AND
EQUIPMENT COST



KSE: SHORT STROKE CYLINDERS
WITH SINGLE ACTING (SPRINGED
FROM BACK)



KSE-A: SHORT STROKE MAGNETIC
CYLINDERS WITH SINGLE ACTING
(SPRINGED FROM BACK)

Example of order:

KSE-A 032-025 M3
Product code Cylinder Ø Stroke Variants from
Standard System

VARIANTS FROM STANDART SYSTEM:

- R1 : Stainless Steel Piston Rod (SS 304-SS 316)
- R4 : Stainless Steel Nut for Piston Rod (SS 304)
- R5: Piston Rod as CK45 (Hard Chrome Plated)
- M1: Extended male Piston Rod Thread
- M3: Special Piston Rod Thread
- M4: Extended Piston Rod
- K1: Seals for Max. 150°C (Viton)
- K4: Piston Rod Seal Viton

Force:

Cylinder Ø mm	Rod Ø mm	Thrust and traction forces (6 Bar)	
		Thrust force (N)	Traction force (N)
20	10	9	118
25	12	13	214
32	16	16	331
40	16	23	588
50	20	30	934
63	20	35	1614
80	25	60	2607
100	30	100	4097

Working Fluid:

Filtered and lubricated or filtered and not lubricated air.

Operating Temperature Range:

Polyurethane (PU) : (-20°C) - (+80°C)
Viton (FKM) : (-30°C) - (+150°C)

Maximum work pressure:

10 Bar

**KSE-A SERIES
SHORT STROKE MAGNETIC SERIES**

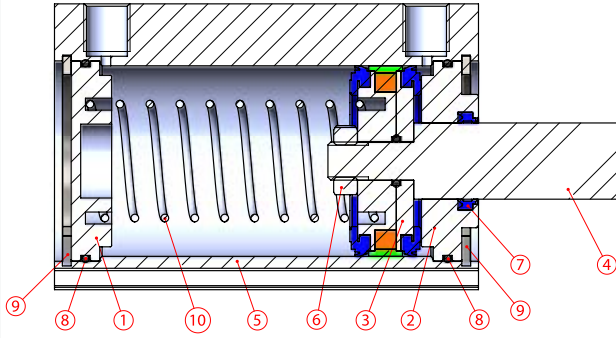

Stroke: Max. 25mm

**KSE SERIES
SHORT STROKE NO MAGNETIC SERIES**

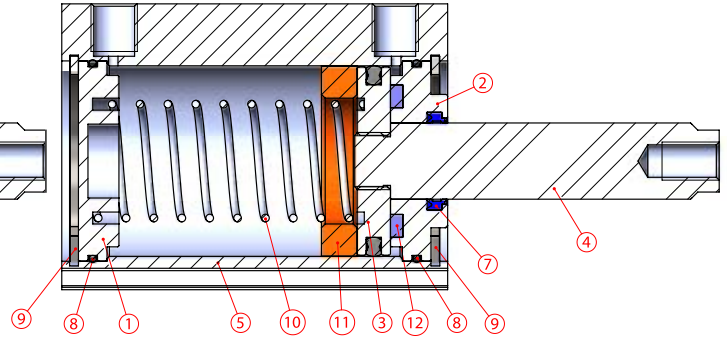

Stroke: Max. 25mm

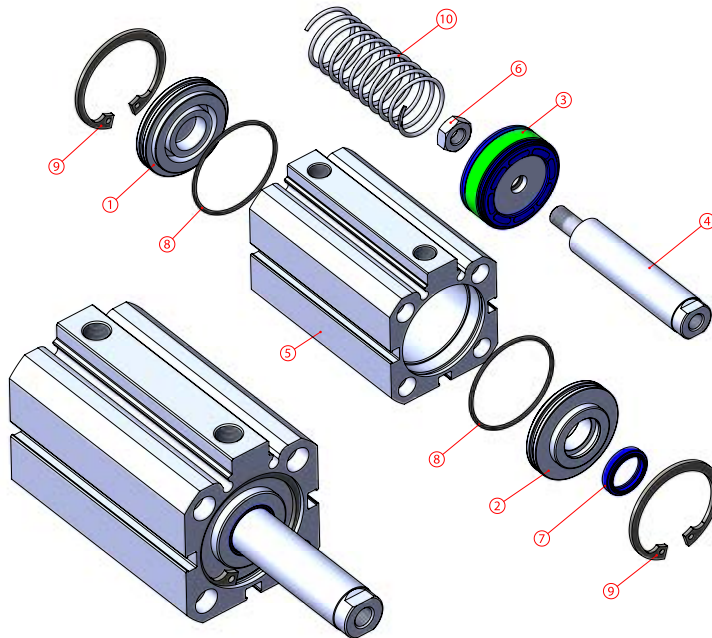

No	Material name	Characteristic		Pc.
		Magnetic	No Magnetic	
1	Rear Head	Bronze - 6082 Al. Eloxal Plated		1
2	Front Head	Bronze - 6082 Al. Eloxal Plated		1
3	Middle Piston	K58 PU + AL. + Polyacetal	6082 Al. + K62-K63 NBR	1
4	Piston Rod	X20Cr13 Hard Chrome Plated		1
5	Tube	Al Mg Si 0,5 + Eloxal Plated		1
6	Nut	Galvanized Steel		1
7	Rod Seal	PU		1
8	Head O-ring	NBR		2
9	Head Circlip	DIN 472 Steel		2
10	Spring	Galvanized Steel		1
11	POM			1
12	PU Bumper		PU 90	1

Not:

- Ø20 - Ø63 Front and Rear Head: Bronze
- Ø80- Ø100 Front and Rear Head: 6082 Al. + Eloxal Plated
- Ø20- Ø25 Magnetic Cylinder Middle Piston: Brass
- Ø32- Ø100 Magnetic Cylinder Middle Piston: K58
- Ø20- Ø100 No Magnetic Cylinder Middle Piston: 6082 Al.+ K62-K63 NBR

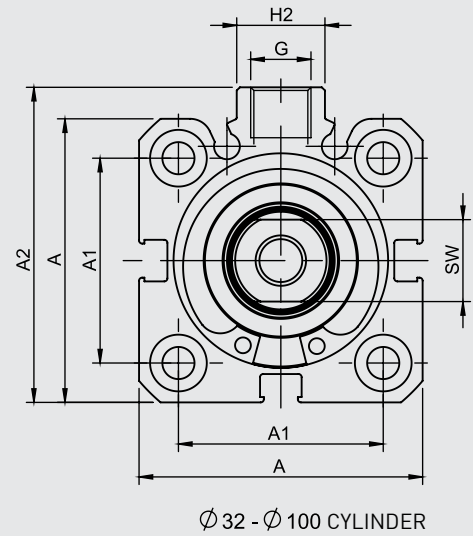
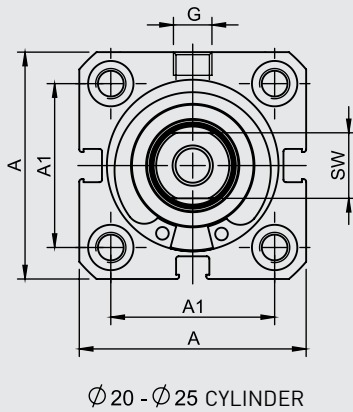
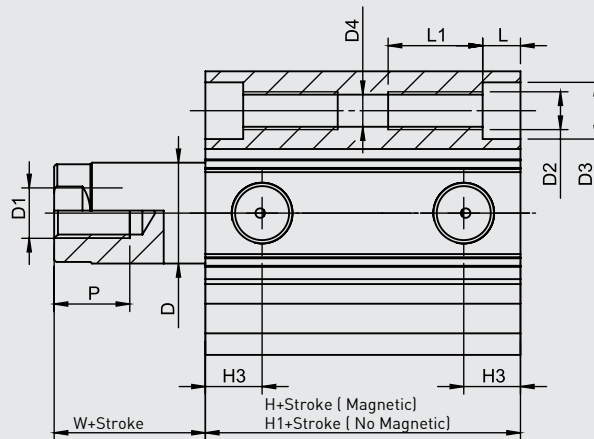

Cylinder Ø mm	A	A1	A2	D Ø	D1 Ø	D2 Ø	D3 Ø	D4 Ø	G	H	H1	H2	H3	L	L1	P	W	SW
20	36	22	-	10	M6	M5	7.5	4.15	M5	32	26	-	7.25	5	10	10	6	9
25	41	26	-	12	M6	M5	7.5	4.15	M5	33	27,5	-	7.25	5	10	10	6	10
32	45	32.5	50	16	M8	M6	9	5.1	1/8"	33	33	14	9	6	12	12	7	13
40	54	38	60	16	M8	M6	9	5.1	1/8"	39	38,5	15	11	6	12	12	7	13
50	64.5	46.5	70	20	M10	M8	11	6.7	1/8"	40.5	40	19	11.5	7	16	16	8	17
63	77.5	56.5	83	20	M10	M8	11	6.7	1/8"	46	41,5	19	12	7	16	16	8	17
80	96.5	72	102	25	M12	M10	13.5	8.6	1/8"	53.5	52,5	25	13.5	9	16	20	10	22
100	115	89	124	30	M12	M10	13.5	8.6	1/4"	62.5	61,5	25	15.5	9	16	20	10	27

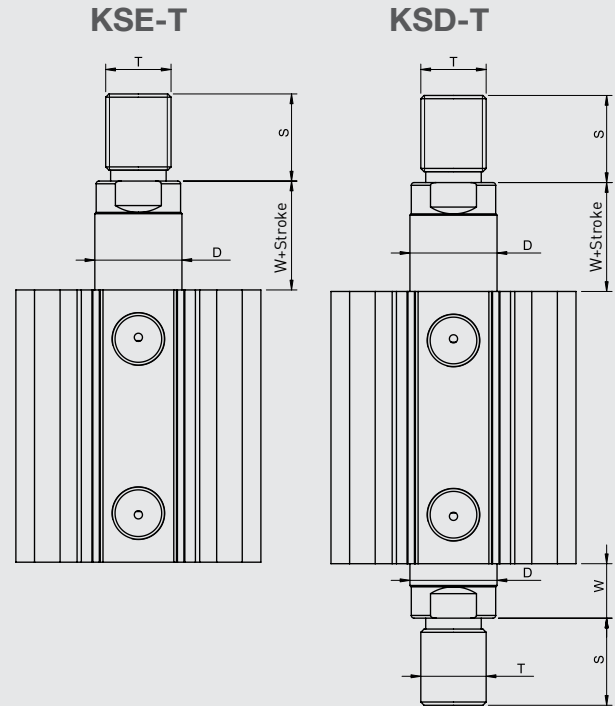
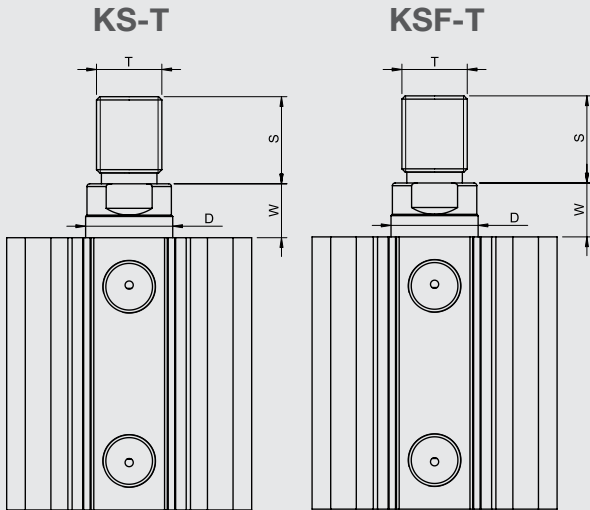
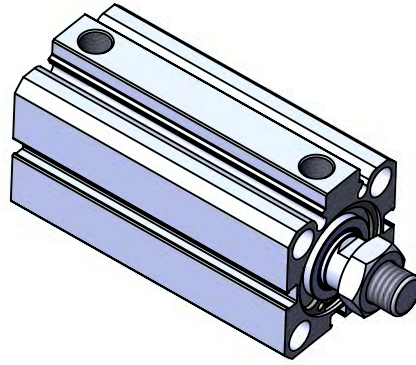

Cylinder type	Cylinder Ø mm	D	S	T	W
KS-KSF KSE-KSD	20	12	12	M8	6
	25	12	14	M10x1.25	6
	32	16	16	M12x1.25	7
	40	16	16	M12x1.25	7
	50	20	22	M16x1.5	8
	63	20	22	M16x1.5	8
	80	25	28	M20x1.5	10
	100	30	28	M20x1.5	10